



# OPERATING INSTRUCTIONS

EN

Translation of the Original

## OKTA 1000 | OKTA 1000 M

Roots pump

**PFEIFFER**  **VACUUM**



---

## Dear Customer,

Thank you for choosing a Pfeiffer Vacuum product. Your new roots pump should support you in your individual application with full performance and without malfunctions. The name Pfeiffer Vacuum stands for high-quality vacuum technology, a comprehensive and complete range of top-quality products and first-class service. From this extensive, practical experience we have gained a large volume of information that can contribute to efficient deployment and to your personal safety.

In the knowledge that our product must avoid consuming work output, we trust that our product can offer you a solution that supports you in the effective and trouble-free implementation of your individual application.

Please read these operating instructions before putting your product into operation for the first time. If you have any questions or suggestions, please feel free to contact [info@pfeiffer-vacuum.de](mailto:info@pfeiffer-vacuum.de).

Further operating instructions from Pfeiffer Vacuum can be found in the [Download Center](#) on our website.

## Disclaimer of liability

These operating instructions describe all models and variants of your product. Note that your product may not be equipped with all features described in this document. Pfeiffer Vacuum constantly adapts its products to the latest state of the art without prior notice. Please take into account that online operating instructions can deviate from the printed operating instructions supplied with your product.

Furthermore, Pfeiffer Vacuum assumes no responsibility or liability for damage resulting from the use of the product that contradicts its proper use or is explicitly defined as foreseeable misuse.

## Copyright

This document is the intellectual property of Pfeiffer Vacuum and all contents of this document are protected by copyright. They may not be copied, altered, reproduced or published without the prior written permission of Pfeiffer Vacuum.

We reserve the right to make changes to the technical data and information in this document.



# Table of contents

<b>1</b>	<b>About this manual</b>	<b>7</b>
1.1	Validity	7
	1.1.1 Applicable documents	7
	1.1.2 Product variants affected	7
1.2	Target group	7
1.3	Conventions	8
	1.3.1 Instructions in the text	8
	1.3.2 Pictographs	8
	1.3.3 Stickers on the product	8
	1.3.4 Abbreviations	9
<b>2</b>	<b>Safety</b>	<b>10</b>
2.1	General safety instructions	10
2.2	Safety instructions	10
2.3	Safety precautions	13
2.4	Product usage limits	14
2.5	Proper use	14
2.6	Foreseeable improper use	14
<b>3</b>	<b>Product description</b>	<b>16</b>
3.1	Functional description	16
3.2	Product identification	16
3.3	Product features	17
3.4	Shipment	17
<b>4</b>	<b>Transportation and Storage</b>	<b>18</b>
4.1	Transporting the vacuum pump	18
4.2	Storing the vacuum pump	19
<b>5</b>	<b>Installation</b>	<b>20</b>
5.1	Installing the vacuum pump	20
5.2	Filling with lubricant	20
5.3	Filling with sealing oil	21
5.4	Connecting the vacuum side	22
5.5	Connecting the fore-vacuum side	23
5.6	Establishing mains connection	23
	5.6.1 Connecting a three phase motor with 6-pin terminal board	24
	5.6.2 Checking the direction of rotation	25
	5.6.3 Connect the PTC thermistor temperature sensor (PTC)	25
<b>6</b>	<b>Operation</b>	<b>27</b>
6.1	Putting the vacuum pump into operation	27
6.2	Switching on the vacuum pump	27
6.3	Adjusting the sealing gas amount	28
6.4	Flushing the suction chamber	28
6.5	Switching off and venting	29
6.6	Re-start (to)	30
<b>7</b>	<b>Maintenance</b>	<b>31</b>
7.1	Maintenance information	31
7.2	Checklist for inspection and maintenance	31
7.3	Changing the lubricant	33
7.4	Changing the sealing oil	34
7.5	Cleaning the suction chamber	35
7.6	Cleaning the overflow valve	36
7.7	Installing the coupling	37
7.8	Installing the coupling for versions with magnetic coupling	38



<b>8</b>	<b>Decommissioning</b>	<b>39</b>
8.1	Shutting down for longer periods	39
8.2	Recommissioning	39
8.3	Disposing of the vacuum pump	39
<b>9</b>	<b>Malfunctions</b>	<b>41</b>
<b>10</b>	<b>Service solutions from Pfeiffer Vacuum</b>	<b>43</b>
<b>11</b>	<b>Spare parts</b>	<b>45</b>
11.1	Set of seals for version with RSSR	45
11.2	Set of seals for version with magnetic coupling	45
11.3	Maintenance kit for version with RSSR	45
11.4	Maintenance kit for version with magnetic coupling	45
<b>12</b>	<b>Accessories</b>	<b>46</b>
12.1	Sealing gas device	46
12.2	Flushing device	46
12.3	Gear space extraction	46
12.4	Protective strainer	46
<b>13</b>	<b>Technical data and dimensions</b>	<b>47</b>
13.1	General	47
13.2	Technical data	47
13.3	Dimensions	48
	<b>Declaration of conformity</b>	<b>50</b>



## List of tables

Tbl. 1:	Stickers on the product	9
Tbl. 2:	Abbreviations used	9
Tbl. 3:	Usage limits of the vacuum pump	14
Tbl. 4:	Features of the roots pumps	17
Tbl. 5:	Max. permissible flushing quantity	29
Tbl. 6:	Maintenance intervals	33
Tbl. 7:	Troubleshooting	42
Tbl. 8:	Available spare parts packages	45
Tbl. 9:	Conversion table: Pressure units	47
Tbl. 10:	Conversion table: Units for gas throughput	47
Tbl. 11:	Technical data Okta 1000 Standard   M	48
Tbl. 12:	Dimensions Okta 1000 Standard   M	49



## List of figures

Fig. 1:	Position of the labels on the product	9
Fig. 2:	Design, construction	16
Fig. 3:	Transporting the vacuum pump	19
Fig. 4:	Filling with lubricant	21
Fig. 5:	Filling sealing oil for radial shaft seal rings	22
Fig. 6:	Delta connection for low voltage	24
Fig. 7:	Star circuit for high voltage	24
Fig. 8:	Check of direction of rotation	25
Fig. 9:	Connection example with PTC thermistor tripping unit	26
Fig. 10:	Drain the lubricant	34
Fig. 11:	Replacing the sealing oil for radial shaft seal rings	35
Fig. 12:	Overflow valve	36
Fig. 13:	Installation instructions gear rim coupling	37
Fig. 14:	Dimension diagram Okta 1000 Standard   M	48



# 1 About this manual



## IMPORTANT

Read carefully before use.  
Keep the manual for future consultation.

## 1.1 Validity

These operating instructions are for customers of Pfeiffer Vacuum. They describe the function of the designated product and provide the most important information for safe usage of the product. The descriptions comply with applicable directives. All information provided in these operating instructions refer to the current development status of the product. The documentation remains valid as long as the customer does not modify the product in any way.

### 1.1.1 Applicable documents

Document	Number
Declaration of conformity	A component of these instructions
Additional information for "M Version"	PW 0142 BN
Supplementary Information for Roots pumps with special overflow valves	PW 0022 BN

### 1.1.2 Product variants affected

These instructions apply for roots pumps of the following versions:

Pump type	Pump designs
Standard version	Standard version: <ul style="list-style-type: none"> <li>• Standard motor</li> <li>• The housing and all parts forming the suction chamber consist of GG and GGG</li> <li>• Connection flanges are designed as ISO flanges</li> <li>• Overflow valve for protection against thermal overload</li> </ul>
M version	Changes to the standard design: <ul style="list-style-type: none"> <li>• Version with magnetic coupling</li> </ul>
Special versions	<ul style="list-style-type: none"> <li>• Various pressure differentials at the overflow valve</li> <li>• Special seal materials which are resistant to aggressive media</li> <li>• Coated pump interior for corrosion protection and/or good anti-sticking properties</li> <li>• special, process-specific lubricants</li> </ul>

## 1.2 Target group

This operating instructions are aimed at all persons performing the following activities on the product:

- transport,
- setup (installation),
- usage and operation,
- decommissioning,
- maintenance and cleaning,
- storage or disposal.

The work described in this document is only permitted to be performed by persons with the appropriate technical qualifications (expert personnel) or who have received the relevant training from Pfeiffer Vacuum.

## 1.3 Conventions

### 1.3.1 Instructions in the text

Usage instructions in the document follow a general structure that is complete in itself. The required action is indicated by an individual step or multi-part action steps.

#### Individual action step

A horizontal, solid triangle indicates the only step in an action.

- ▶ This is an individual action step.

#### Sequence of multi-part action steps

The numerical list indicates an action with multiple necessary steps.

1. Step 1
2. Step 2
3. ...

### 1.3.2 Pictographs

Pictographs used in the document indicate useful information.



Note



Tip



### 1.3.3 Stickers on the product

This section describes all the stickers on the product along with their meaning.

<p><b>PFEIFFER</b> VACUUM D-35641 Asslar</p> <p>Mod.: Okta 1000 Mod.-No.: PP W41 ... Ser. -No.: 143.....</p> <p>n: max. 4500 1/min Oil: P3 2,9 l S(N): max. 1775 m<sup>3</sup>/h Weight: 240 kg</p> <p>Made in Germany 02/2019 CE</p>	<p><b>Rating plate (example)</b> The rating plate is located on the front side above the sight glass</p> <p><b>Motor rating plate (not shown)</b></p>
<p>Vor Inbetriebnahme Pumpe mit Öl füllen Fill the pump with oil before putting into operation Remplir la pompe d'huile avant la mise en route</p>	<p><b>Sticker (red)</b> Before commissioning, fill the gear and bearing chambers with lubricant</p>
<p>Achtung! nur mit D1 befüllen Attention! only D1 to be used</p>	<p><b>Sticker (blue) – special lubricant only</b> Caution: fill with <b>D1</b> only</p>
<p>Achtung! nur mit F5 befüllen Attention! only F5 to be used</p>	<p><b>Adhesive label (orange) – only in case of special lubricants</b> Caution: fill with <b>F5</b> only</p>





	<p><b>Warning hot surface</b></p> <p>This sticker warns of injuries caused by high temperatures in case of touching without protection during operation.</p>
	<p><b>Warning of magnetic field</b></p> <p>This adhesive label warns of injuries to people with pacemakers.</p>

Tbl. 1: Stickers on the product

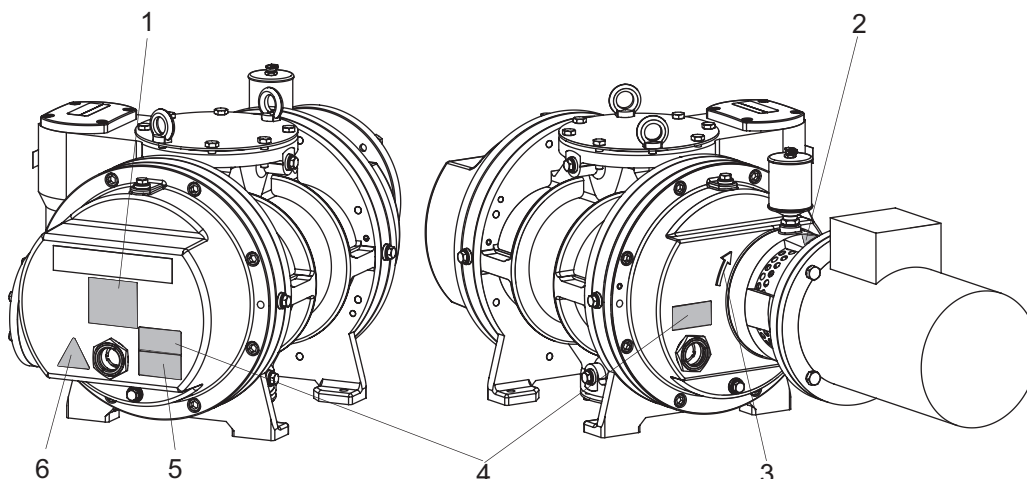

Fig. 1: Position of the labels on the product

- |   |                            |
|---|----------------------------|
| 1 Rating plate                                    | 4 Fill lubricant note      |
| 2 Magnetic field warning sign                     | 5 Note D1/F5 lubricant     |
| 3 Direction of rotation arrow (cast in the cover) | 6 Hot surface warning sign |

### 1.3.4 Abbreviations

Abbreviation	Explanation
PTC	Temperature-dependent resistor (Positive Temperature Coefficient)
M version	Roots pumps with magnetic coupling
RSSR	Radial shaft seal ring
WAF	width across flats
E	Clearance between both coupling halves
GGG	Spheroidal graphite cast iron
GG	Cast iron with lamellar graphite
FPM	Fluoropolymer rubber
PN	Nominal pressure stage (pressure nominal)
ISO	International Organization for Standardization
DIN	German Institute for Standardization (Deutsches Institut für Normung)
f	Rotation speed value of a vacuum pump (frequency, in rpm or Hz)
p	Intake pressure or general pressure in [hPa]
OI	Operating instructions
SI	Service instructions

Tbl. 2: Abbreviations used

## 2 Safety

### 2.1 General safety instructions

This document includes the following four risk levels and one information level.

<b>⚠ DANGER</b>	
<p><b>Imminent danger</b> Indicates a hazardous situation which, if not avoided, will result in death or serious injury.</p> <ul style="list-style-type: none"> <li>▶ Instructions on avoiding the hazardous situation</li> </ul>	
<b>⚠ WARNING</b>	
<p><b>Possibly imminent danger</b> Indicates a hazardous situation which, if not avoided, could result in death or serious injury.</p> <ul style="list-style-type: none"> <li>▶ Instructions on avoiding the hazardous situation</li> </ul>	
<b>⚠ CAUTION</b>	
<p><b>Possibly imminent danger</b> Indicates a hazardous situation which, if not avoided, could result in minor or moderate injury.</p> <ul style="list-style-type: none"> <li>▶ Instructions on avoiding the hazardous situation</li> </ul>	
<b>NOTICE</b>	
<p><b>Danger of property damage</b> Notice is used to address practices not related to physical injury.</p> <ul style="list-style-type: none"> <li>▶ Instructions on avoiding property damage</li> </ul>	
<div style="border: 1px solid black; padding: 5px; display: inline-block;">  </div>	<p>Notes, tips or examples indicate important information on the product or on this document.</p>

### 2.2 Safety instructions

All safety instructions in this document are based on the results of the risk assessment carried out in accordance with Machinery Directive 2006/42/EC Annex I and EN ISO 12100 Section 5. Where applicable, all life cycle phases of the product were taken into account.

#### Risks during transport

<b>⚠ WARNING</b>
<p><b>Risk of serious injury from swinging, toppling or falling objects</b> During transport, there is a risk of crushing and impact on swinging, toppling or falling objects. There is a risk of injuries to limbs, up to and including bone fractures and head injuries.</p> <ul style="list-style-type: none"> <li>▶ Secure the danger zone if necessary.</li> <li>▶ Pay attention to the center of gravity of the load during transport.</li> <li>▶ Ensure even movements and moderate speeds.</li> <li>▶ Observe safe handling of the transport devices.</li> <li>▶ Avoid sloping attachment aids.</li> <li>▶ Never stack products.</li> <li>▶ Wear protective equipment, e.g. safety shoes.</li> </ul>



## Risks during installation

**⚠ DANGER****Danger to life from electric shock**

Contact with exposed and live elements generate an electric shock. Incorrect connection of the mains supply leads to the risk of live housing parts that can be touched. There is a risk to life.

- ▶ Before the installation, check that the connection leads are voltage-free.
- ▶ Make sure that electrical installations are only carried out by qualified electricians.
- ▶ Provide adequate grounding for the device.
- ▶ After connection work, carry out an earthed conductor check.

**⚠ WARNING****Risk of crushing from rotating parts**

Fingers and hands may be caught by rotating pistons within the connection flange. This results in severe injuries.

- ▶ Keep limbs out of the reach of the roots pump.

**⚠ CAUTION****Danger of injury from bursting as a result of high pressure in the exhaust line**

Faulty or inadequate exhaust pipes lead to dangerous situations, e.g., increased exhaust pressure. There is a danger of bursting. Injuries caused by flying fragments, the escaping of high pressure, and damage to the unit cannot be excluded.

- ▶ Route the exhaust line without shut-off units.
- ▶ Observe the permissible pressures and pressure differentials for the product.
- ▶ Check the function of the exhaust line on a regular basis.

**⚠ CAUTION****Risk of injury from loss of stability**

During setup, there is a risk of injury from tipping, if the vacuum pump is not anchored on the standing surface.

- ▶ Secure the vacuum pump using suitable lifting gear.
- ▶ Wear personal protective equipment.

**⚠ CAUTION****Danger of injury from moving parts**

After a power failure or a standstill as a result of overheating, the motor restarts automatically. There is a risk of injury to fingers and hands if they enter the operating range of rotating parts.

- ▶ Safely disconnect motor from the mains.
- ▶ Secure the motor against reactivation.
- ▶ Dismantle the vacuum pump for inspection, away from the system if necessary.

## Risks during operation

**⚠ WARNING****Danger of poisoning due to toxic process media escaping from the exhaust pipe**

During operation with no exhaust line, the vacuum pump allows exhaust gases and vapors to escape freely into the air. There is a risk of injury and fatality due to poisoning in processes with toxic process media.

- ▶ Observe the pertinent regulations for handling toxic process media.
- ▶ Safely purge toxic process media via an exhaust line.
- ▶ Use appropriate filter equipment to separate toxic process media.



**⚠ WARNING**

**Risk of crushing on rotating parts when reaching into the open flange**

The pistons continue to run in the vacuum after switching off the motor, and can trap fingers and hands within their reach.

- ▶ Wait until the vacuum pump comes to a complete standstill.
- ▶ Secure the vacuum pump against re-start.

**⚠ CAUTION**

**Danger of burns on hot surfaces**

Depending on the operating and ambient conditions, the surface temperature of the vacuum pump can increase to above 70 °C.

- ▶ Provide suitable touch protection.

**⚠ CAUTION**

**Health hazard from increased noise emission**

Remaining in the close proximity of the vacuum pump for a sustained period of time may cause hearing damage.

- ▶ Ensure adequate sound insulation.
- ▶ Wear hearing protection.

**Risks during maintenance, decommissioning and malfunctions**

**⚠ WARNING**

**Danger of injury from strong magnetic field**

There is a risk of injury for people with pacemakers and medical implants.

- ▶ Make sure that such individuals do not enter the sphere of influence ( $\leq 2$  m) of the magnetic field.
- ▶ Identify rooms in which magnetic couplings are openly accessible with the symbol: **"No access for people with pacemakers"**.
- ▶ Always keep disassembled couplings away from computers, data carriers, and other electronic components.

**⚠ WARNING**

**Health hazard through poisoning from toxic contaminated components or devices**

Toxic process media result in contamination of devices or parts of them. During maintenance work, there is a risk to health from contact with these poisonous substances. Illegal disposal of toxic substances causes environmental damage.

- ▶ Take suitable safety precautions and prevent health hazards or environmental pollution by toxic process media.
- ▶ Decontaminate affected parts before carrying out maintenance work.
- ▶ Wear protective equipment.

**⚠ WARNING**

**Risk of crushing from rotating parts**

Fingers and hands may be caught by rotating pistons within the connection flange. This results in severe injuries.

- ▶ Keep limbs out of the reach of the roots pump.



**⚠ WARNING****Health hazard and environmental damage from toxic contaminated lubricant**

Toxic process media can cause lubricant contamination. When changing the lubricant, there is a health hazard due to contact with poisonous substances. Illegal disposal of toxic substances causes environmental damage.

- ▶ Wear suitable personal protective equipment when handling these media.
- ▶ Dispose of the lubricant according to locally applicable regulations.

**⚠ WARNING****Danger of injury due to exposed rotating parts**

In the operating range of the motor coupling, there is a danger of clothing being caught and wound up.

- ▶ When assembling the motor and coupling, make sure that the coupling protection is seated correctly.
- ▶ Wear correct clothing.

**⚠ CAUTION****Scalding from hot lubricant**

Danger of scalding when draining lubricant if it comes into contact with the skin.

- ▶ Wear personal protective equipment.
- ▶ Use a suitable collection receptacle.

## 2.3 Safety precautions

**Duty to provide information on potential dangers**

The product holder or user is obliged to make all operating personnel aware of dangers posed by this product.

Every person who is involved in the installation, operation or maintenance of the product must read, understand, and adhere to the safety-related parts of this document.

**Infringement of conformity due to modifications to the product**

The Declaration of Conformity from the manufacturer is no longer valid if the operator changes the original product or installs additional equipment.

- Following installation into a system, the operator is required to check and re-evaluate as necessary the conformity of the overall system in the context of the relevant European Directives before commissioning that system.

**General safety precautions**

- ▶ Do not expose body parts to the vacuum.
- ▶ Check all safety measures at regular intervals.
- ▶ Observe the safety and accident prevention regulations, if necessary wear personal protective equipment.
- ▶ Always ensure a secure connection to the earthed conductor (PE), protection class I.
- ▶ Never operate the vacuum pump with open vacuum flange.
- ▶ Provide suitable touch protection, if the surface temperature exceeds 70°C.
- ▶ Provide appropriate noise protection measures in case the sound pressure level requires this.
- ▶ Before working on the vacuum connection, wait until the rotor is at a complete standstill (rotation speed  $f = 0$ ).
- ▶ Do not carry out your own conversions or modifications on the vacuum pump.
- ▶ Before returning the vacuum pump, observe the notes in the chapter Service.



## 2.4 Product usage limits

Parameter	Okta
Installation location	<ul style="list-style-type: none"> <li>• Indoors, protected against:                             <ul style="list-style-type: none"> <li>– dust deposits</li> <li>– falling objects</li> <li>– fire-fighting water</li> </ul> </li> <li>• Outdoors, protected against:                             <ul style="list-style-type: none"> <li>– falling objects</li> <li>– direct influence of weather such as rain, splash water, strong drafts and sunlight</li> <li>– fire-fighting water</li> <li>– lightning strike</li> </ul> </li> </ul>
Installation altitude	max. 2,000 m above sea level, at installation altitudes > 1,000m above m.s.l. and an ambient temperature of 40 °C the rated power of the motor reduces by around 10 %
Ambient temperature	+5 °C to +40 °C
Relative air humidity	max. 85 % (depending on the motor version)
Gas temperature, pressure side, max.	+200 °C
Intake pressure, max.	< 1,100 hPa (abs.)
Orientation	Horizontal

**Tbl. 3: Usage limits of the vacuum pump**

## 2.5 Proper use

- ▶ Use the vacuum pump for vacuum generation only.
- ▶ When pumping media with an oxygen concentration level of > 21 %, only use perfluorinated, synthetic oils (F5) as lubricant.
- ▶ Depending on the process and if necessary, use sealing gas.
  - Evacuating high-boiling media (e.g. solvents) degrades the lubricant.
- ▶ Operate the vacuum pump within application limits (see: Product usage limits and Technical data).
- ▶ Adhere to the installation, commissioning, operating, and maintenance instructions.
- ▶ Use only accessory parts recommended by Pfeiffer Vacuum.

## 2.6 Foreseeable improper use

Improper use of the product invalidates all warranty and liability claims. Improper use is any, even unintended, use, which is contrary to the product purpose; and in particular:

- Transport, installation or operation of the vacuum pump in an impermissible spatial position
- Pumping media that can corrode or not be withstood by vacuum pump materials.  
Components contained in the suction chamber are cast iron, steel, and stainless steel. Seals are FKM (alternative seals available on request).
- Pumping explosive media
- Pumping radioactive media
- Pumping media prone to exothermic reactions
- Pumping media that introduce an ignition source to the suction chamber
- Pumping media that can cause adhesive deposits to form in the suction chamber, or the pistons to start up or jam
- Pumping fluids - flushing media for cleaning are permissible
- Using the vacuum pump to generate pressure
- Using the vacuum pump in systems in which sporadic loads and vibrations or periodic forces act on the unit
- Use of the vacuum pump in potentially explosive atmospheres
- Use of the vacuum pump in areas with strong electrical, magnetic or electromagnetic fields



- Use of the vacuum pump with open vacuum and/or fore-vacuum flange open to the atmosphere
- Using lubricants not specified by Pfeiffer Vacuum
- Using pipes to lift the vacuum pump
- Use of accessories or spare parts that are not listed in these instructions
- Using the vacuum pump as a climbing aid.



## 3 Product description

### 3.1 Functional description

The operating principle of the Roots pumps is based on two synchronous pistons which rotate in a housing without touching. The pumping effects arise as a result of the opposing rotation of the two figure-of-eight shaped rolling pistons. While suction chambers are formed between the rolling pistons and the housing, the rolling pistons continuously form a mutual seal without touching each other or the housing. This opposing yet synchronised movement of the rolling pistons is achieved by means of a pair of gears mounted on the extended shaft ends. Lubrication is limited to the two bearing and gear chambers which are arranged separately from the suction chambers. As the roots pump is not capable of compressing against atmospheric pressure, it needs to be operated in conjunction with a backing pump connected upstream.

Roots pumps of the M series are equipped with a magnetic coupling.

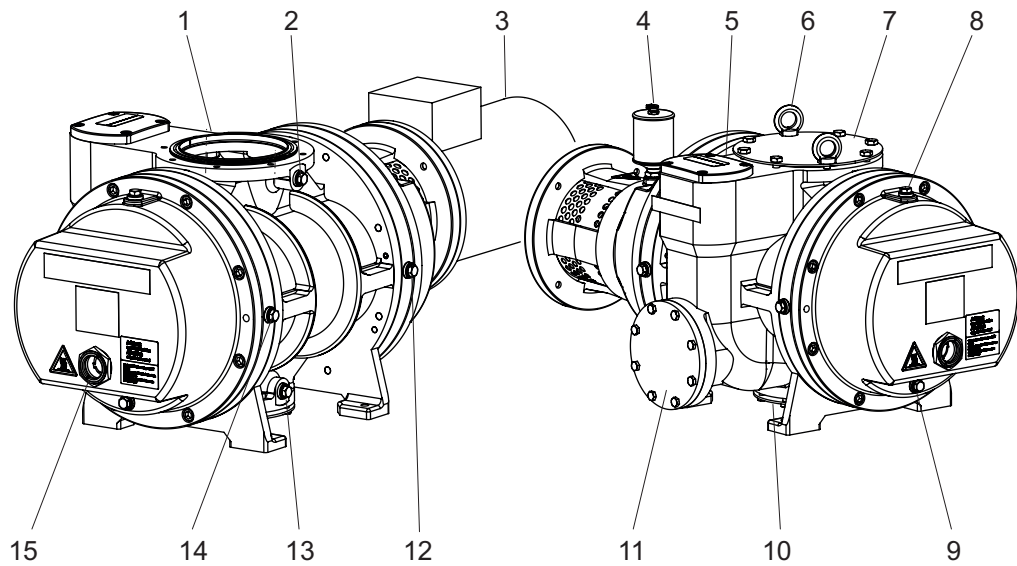

**Fig. 2: Design, construction**

- |                                      |  |
|--------------------------------------|--|
| 1 Vacuum flange                      | 9 Lubricant drain plug                     |
| 2 Measurement connection vacuum side | 10 Fore-vacuum flange                      |
| 3 Motor                              | 11 Optional fore-vacuum connection         |
| 4 Oiler for version with RSSR        | 12 Sealing gas connection motor side       |
| 5 Overflow valve                     | 13 Measurement connection fore-vacuum side |
| 6 Eye bolt                           | 14 Sealing gas connection bearing side     |
| 7 Cardboard cover disk               | 15 Sight glass                             |
| 8 Lubricant filling plug             |  |

### 3.2 Product identification

To ensure for a clear identification of the product when communicating with Pfeiffer Vacuum, always keep all of the information on the rating plate to hand.

The following information is shown on the rating plate:

- Pump model
- Model number
- Type and quantity of the lubricant
- Max. allowable pump rotation speed
- Date of manufacture
- Input voltage range





### 3.3 Product features

Flange types	Vacuum connection	Fore-vacuum connection	Sealing gas connection	Measurement connection
Okta 1000	DN 160 ISO-F	DN 100 ISO-F	4 × G 3/8"	2 × G 3/8"
Okta 1000 M				
Okta 1000 pressure surge protected	DN 150 PN 16	DN 100 PN 16		
Okta 1000 M pressure surge protected				

Tbl. 4: Features of the roots pumps

### 3.4 Shipment

- Roots pump
- Motor-side coupling half for Roots pumps without motor
- Seal for the connection flange
- Cover disks for the connecting flanges
- Screw kit for the connection flange
- 2 eye bolts for lifting the Roots pump
- Lubricant P3 (standard version)
- Operating instructions



## 4 Transportation and Storage

### 4.1 Transporting the vacuum pump

#### **WARNING**

##### **Risk of serious injury from swinging, toppling or falling objects**

During transport, there is a risk of crushing and impact on swinging, toppling or falling objects. There is a risk of injuries to limbs, up to and including bone fractures and head injuries.

- ▶ Secure the danger zone if necessary.
- ▶ Pay attention to the center of gravity of the load during transport.
- ▶ Ensure even movements and moderate speeds.
- ▶ Observe safe handling of the transport devices.
- ▶ Avoid sloping attachment aids.
- ▶ Never stack products.
- ▶ Wear protective equipment, e.g. safety shoes.



#### **Instructions for safe transport**

- Only remove the protective cover for the connection flange once the pipes have been mounted.
- Fill the gear and bearing chambers with lubricant only once the final installation position is reached.



Pfeiffer Vacuum recommends keeping the transport packaging and original protective cover.

#### **General information regarding safe transport**

1. Observe weight specified on the rating plate.
2. Where possible, always transport or ship the roots pump in its original packaging.
3. Remove the protective cover only immediately prior to installation.

#### **Transporting the vacuum pump in its packaging**

1. Use a pallet truck to transport the vacuum pump in its packaging.
2. Note the center of gravity of the load.
3. Observe safe handling of manually operated transport devices.
4. Ensure harmonious movements and moderate speeds.
5. Ensure a flat substrate.
6. Wear protective equipment, e.g. safety shoes.



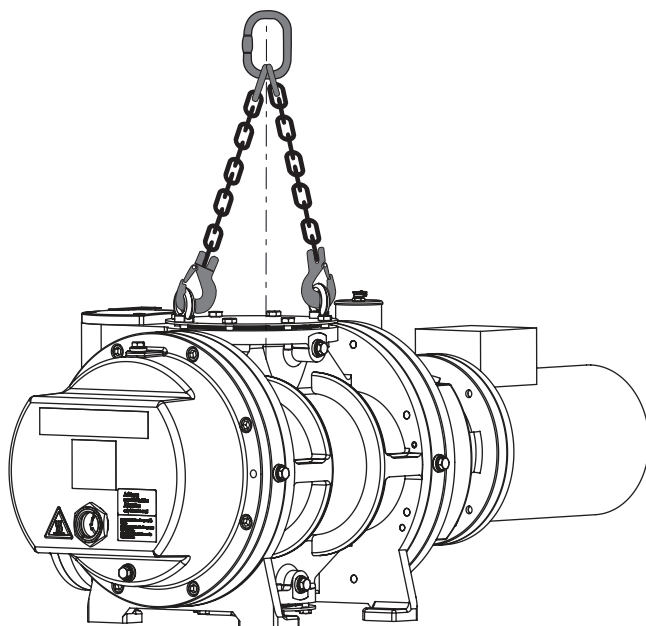

**Fig. 3: Transporting the vacuum pump**

#### **Transporting the vacuum pump without its packaging**

2 eye bolts are included in the shipment, which are firmly bolted to the vacuum pump ex-factory.

1. Unpack the vacuum pump.
2. Attach suitable lifting tools to both eye bolts.
3. Pay attention to the correct use and fastening of the lifting equipment.
4. Lift the vacuum pump out of the transport packaging vertically.
5. If necessary, remove the eye bolts after transport and installation.
  - Keep the eye bolts for future use.

## **4.2 Storing the vacuum pump**

The roots pumps do not have **any corrosion protection** on the inside. If you intend to store the roots pump for longer periods, we recommend that you use a special corrosion protection agreed with us.

#### **Procedure**

1. Close both connection flanges.
2. Check that the other openings are sealed safely, e.g. sealing gas and measurement connections.
3. Store the roots pump only in dry, dust-free rooms, within the specified ambient conditions:
  - In rooms with humid or aggressive atmospheres, seal the roots pump airtight in a plastic bag, together with a drying agent.
  - After a storage period of 2 years, Pfeiffer Vacuum recommends changing the lubricant.

The best corrosion protection for the roots pump is achieved by evacuating and then filling the suction chamber with nitrogen.



## 5 Installation

### 5.1 Installing the vacuum pump

#### **⚠ CAUTION**

##### **Risk of injury from loss of stability**

During setup, there is a risk of injury from tipping, if the vacuum pump is not anchored on the standing surface.

- ▶ Secure the vacuum pump using suitable lifting gear.
- ▶ Wear personal protective equipment.

##### **General notes for the installation of vacuum components**

- ▶ Choose an installation location that permits access to the product and to supply lines at all times.
- ▶ Observe the ambient conditions given for the area of use.
- ▶ Provide the highest possible level of cleanliness during assembly.
- ▶ Ensure that flange components during installation are grease-free, dust-free and dry.

##### **Procedure**

1. Check the carrying capacity of the floor at the installation location.
2. Place the vacuum pump on a flat, horizontal and fixed surface, to safeguard the lubricant supply.
  - Reference surface is the vacuum flange.
3. Screw the 4 feet of the vacuum pump on level with the standing surface.
4. If necessary, use adjustment elements from the Pfeiffer Vacuum [accessories range](#) for mounting the feet horizontally.
5. When doing so, make sure that the vacuum pump is not tensioned.
6. When installing the pump in a closed housing, ensure adequate air circulation.
7. Keep both sight glasses freely accessible for checks and maintenance.
8. Ensure that the motor rating plate remains accessible at all times for a clear view of the voltage and frequency specifications.
9. Maintain the minimum distances to bordering surfaces to guarantee sufficient air circulation.
10. Leave the filling/drain holes and sight glasses freely accessible.
11. Fill with lubricant prior to first commissioning.

### 5.2 Filling with lubricant

#### **⚠ WARNING**

##### **Danger of poisoning from toxic vapors**

Igniting and heating synthetic lubricants generates toxic vapors. Danger of poisoning if inhaled.

- ▶ Observe the application instructions and precautions.
- ▶ Do not allow tobacco products to come into contact with the lubricant.

#### **NOTICE**

##### **Property damage from using non-approved lubricant**

Attainment of product-specific performance data is not ensured. If non-approved lubricant is used, all liability and warranty claims against Pfeiffer Vacuum are excluded.

- ▶ Use approved lubricant only.
- ▶ Use other application-specific lubricant only after consultation with Pfeiffer Vacuum.

The type of lubricant specified for the gear and bearing chambers, and the fill quantity for the entire roots pump are shown on the rating plate. Only the lubricant used during initial installation is permissible. Subsequent change is possible only after consultation with Pfeiffer Vacuum.



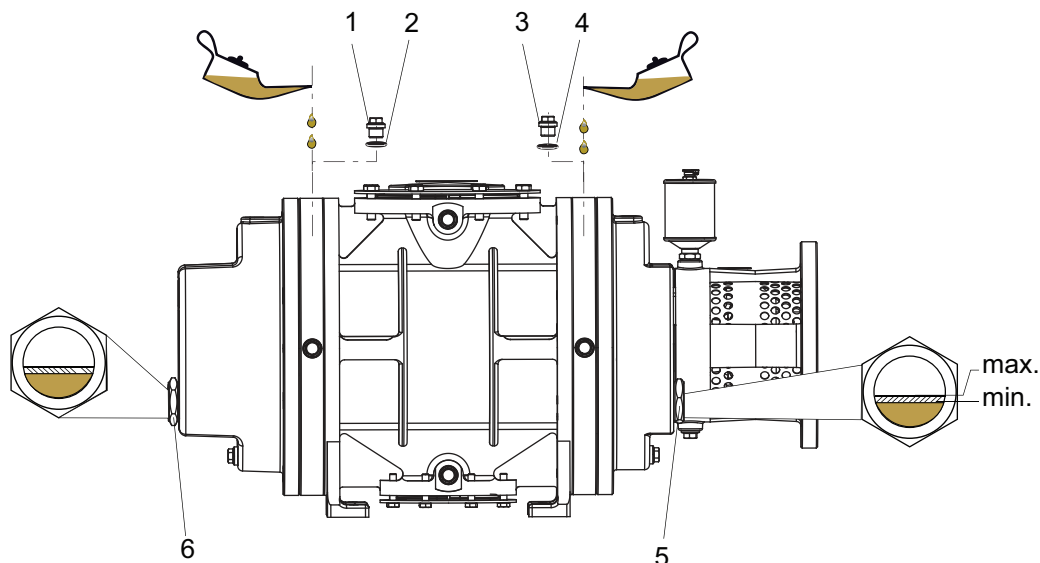

**Fig. 4: Filling with lubricant**

- |                          |                             |
|--------------------------|-----------------------------|
| 1 Lubricant filling plug | 4 O-ring                    |
| 2 O-ring                 | 5 Sight glass, motor side   |
| 3 Lubricant filling plug | 6 Sight glass, gearbox side |

#### Permissible lubricants

- P3 for standard version
- D1 for special applications (such as higher operating temperatures)
- F5 for corrosive gas model
- Other lubricants on request

#### Required tools

- Open-end wrench, 17 mm WAF
- Calibrated torque wrench (tightening factor  $\leq 2.5$ )

#### Procedure

1. Unscrew and remove the lubricant filler screws.
2. Fill the lubricant on both sides while observing the sight glass.
  - Fill levels for the first fill: approx. 5 mm above the sight glass middle.
3. Seal the filler screws.
  - Tightening torque: **32 Nm**
4. Check the fill level during operation in the final vacuum.
5. If necessary, top up the lubricant only when the Roots pump is switched off and flooded.

## 5.3 Filling with sealing oil



#### Versions with radial shaft seal ring:

This section is only valid for Roots pumps with radial shaft seal ring. The version with magnetic coupling "M" does not have a lubricator.



#### Overfilling the oiler

The lubricant expands when the roots pump heats up, which could cause lubricant to leak if overfilled.

Oiler fill level with roots pump in cold state: to max. halfway.

The shaft feedthrough of the drive shaft is sealed with purge oil-covered radial shaft seal rings and fed by a lubricator on the lantern. The sealing oil type is the same as the lubricant.



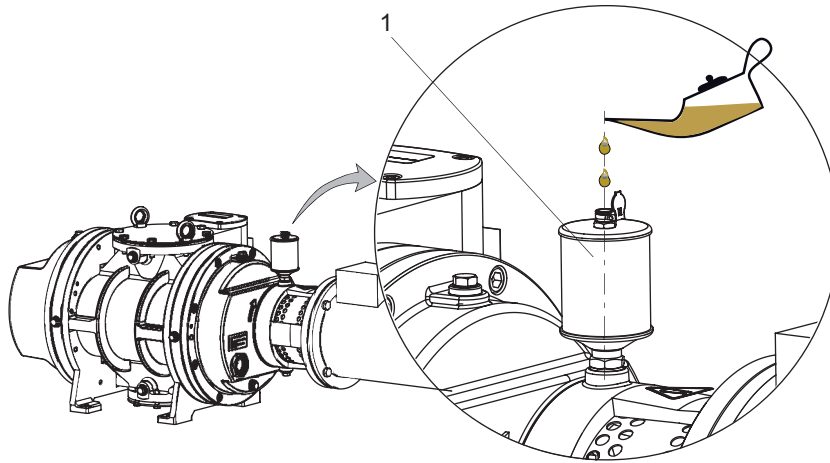

**Fig. 5: Filling sealing oil for radial shaft seal rings**

1 Oiler

**Consumable**

- Sealing oil (lubricant)

**Procedure**

1. Open the filler flap on the oiler.
2. Fill the oiler with lubricant to max. halfway.
3. Close the filler flap.
4. Always make sure that the lubricator is screwed tightly to the vacuum pump.

## 5.4 Connecting the vacuum side

**⚠ WARNING**

**Risk of crushing from rotating parts**

Fingers and hands may be caught by rotating pistons within the connection flange. This results in severe injuries.

- ▶ Keep limbs out of the reach of the roots pump.

**NOTICE**

**Property damage from intake of solid particles**

During commissioning, there is a risk of damage to the suction chamber from dirt from the system or the pipes.

- ▶ Use a suitable protective strainer ("start-up strainer") in the intake flange.
- ▶ Ensure that this strainer is only removed when the risk of solid particles entering the vacuum pump can be excluded.
  - Observe any pumping speed decrease.

**Procedure**

1. Degrease the connection flange.
2. Clear welded lines of any tinder, loose parts or similar before installation.
3. Establish the shortest possible connection between the roots pump and vacuum chamber; equivalent to the nominal flange diameter as a minimum.
4. Route the piping between the vacuum pump and vacuum chamber so that it remains as short as possible; at a minimum, the nominal diameter of the pump flange.
5. Select a larger nominal diameter for pipe lengths > 5 m.
6. Support or suspend the piping to the vacuum pump so that no piping system forces act on the vacuum pump.
7. Always use **all** prescribed screws to fasten the flange.



## 5.5 Connecting the fore-vacuum side

### ⚠ WARNING

#### Risk of crushing from rotating parts

Fingers and hands may be caught by rotating pistons within the connection flange. This results in severe injuries.

- ▶ Keep limbs out of the reach of the roots pump.

### ⚠ CAUTION

#### Danger of injury from bursting as a result of high pressure in the exhaust line

Faulty or inadequate exhaust pipes lead to dangerous situations, e.g., increased exhaust pressure. There is a danger of bursting. Injuries caused by flying fragments, the escaping of high pressure, and damage to the unit cannot be excluded.

- ▶ Route the exhaust line without shut-off units.
- ▶ Observe the permissible pressures and pressure differentials for the product.
- ▶ Check the function of the exhaust line on a regular basis.

#### Procedure

1. Choose a minimum pipe cross section equal to the nominal diameter of the pressure flange.
2. Clear welded lines of any tinder, loose parts or similar before installation.
3. Route the pipes such that no mechanical tension can act on the roots pump or the backing pump.
4. Install a bellows in the piping if necessary.
5. Ensure that mating flanges are in a parallel position.
6. Install the pipes downward from the roots pump, so that condensate does not flow back into the roots pump.
7. Install a condensate separator if necessary.
8. If an air trap is created in the system, then install a condensate drain facility at the lowest point.

## 5.6 Establishing mains connection

### ⚠ DANGER

#### Danger to life from electric shock

Contact with exposed and live elements generate an electric shock. Incorrect connection of the mains supply leads to the risk of live housing parts that can be touched. There is a risk to life.

- ▶ Before the installation, check that the connection leads are voltage-free.
- ▶ Make sure that electrical installations are only carried out by qualified electricians.
- ▶ Provide adequate grounding for the device.
- ▶ After connection work, carry out an earthed conductor check.

### ⚠ WARNING

#### Danger to life from electric shock due to improperly performed installation

The device uses voltage that is dangerous on contact as the electrical power supply. Potentially fatal situations arise due to unsafe or incorrectly installation when reaching into the device.

- ▶ Ensure that the system is safely integrated into an emergency off safety circuit.
- ▶ Do not carry out any unauthorized modifications or changes to the device.

### ⚠ CAUTION

#### Danger of injury from moving parts

After a power failure or a standstill as a result of overheating, the motor restarts automatically. There is a risk of injury to fingers and hands if they enter the operating range of rotating parts.

- ▶ Safely disconnect motor from the mains.
- ▶ Secure the motor against reactivation.
- ▶ Dismantle the vacuum pump for inspection, away from the system if necessary.



**NOTICE**

**Risk of damage from excess voltage!**

Incorrect or excessive mains voltage will destroy the motor.

- ▶ Always observe the motor rating plate specifications.
- ▶ Route the mains connection in accordance with locally applicable provisions.
- ▶ Always provide a suitable mains fuse to protect the motor and supply cable in the event of a fault.
  - Pfeiffer Vacuum recommends the circuit breaker type "K" with slow tripping characteristic.

**NOTICE**

**Motor damage from overheating**

Limited motor fan cooling capacity, caused by low speeds, causes the motor to overheat.

- ▶ During operation with frequency converter, observe the rotation speed range specified in the technical data.

Depending on the pump type, different motor designs or mains voltages can be used:

- Three-phase motor with thermistor temperature sensor (PTC), without switch and mains cable

**5.6.1 Connecting a three phase motor with 6-pin terminal board**

**NOTICE**

**Risk of damage from high starting torque**

The specific load behavior of the vacuum pump requires direct on-line starting at full motor power. Engine damage can occur if a different starting circuit is used.

- ▶ Always start the motor directly.
- ▶ **Never** use a star-delta start-up circuit.

Ports U1 – L2, V1 – L1 and W1 – L3 rotate the motor shaft clockwise when looking at the motor fan.

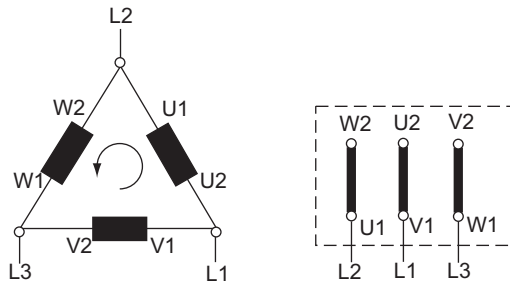

**Fig. 6: Delta connection for low voltage**

The 3 phases are connected in series and the connection points connected to the mains. The voltage per phase is equal to the mains voltage, while the mains current is  $\sqrt{3}$  times the phase current. The delta connection is marked with the  $\Delta$  symbol. The voltage between the incoming mains supply lines is called mains voltage. The mains current is the current flowing in the incoming supply lines.

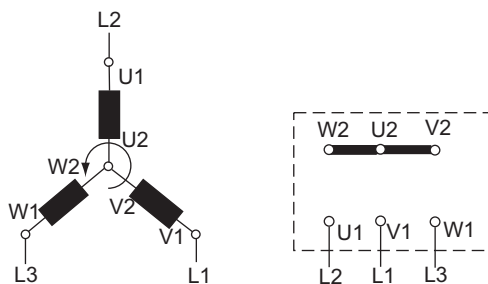

**Fig. 7: Star circuit for high voltage**

The ends of the 3 phases are connected in the star point. The terminal voltage is  $\sqrt{3}$  times the phase voltage, the mains current is equal to the phase current. The star circuit is marked with the Y symbol.





## 5.6.2 Checking the direction of rotation

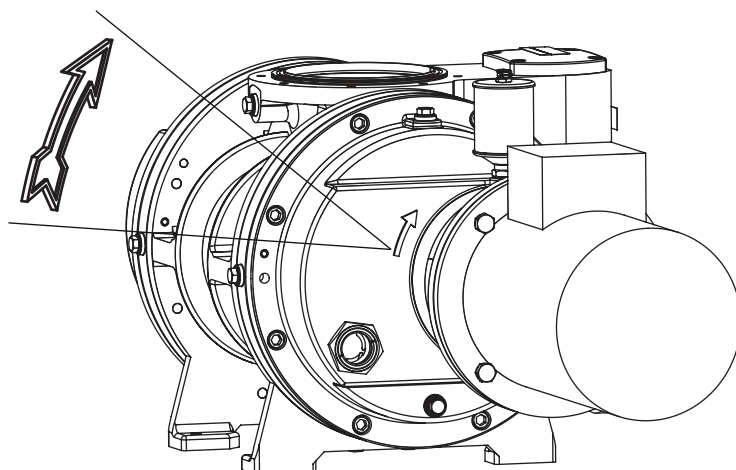

Fig. 8: Check of direction of rotation

### Procedure

When switching on for the first time, check the roots pump direction of rotation.

1. Switch the vacuum pump on briefly (2 to 3 seconds)
  - The motor and coupling must rotate clockwise (see directional arrow on housing cover).
2. If the direction of rotation is incorrect, swap the 2 phases of the connection cable in the terminal box.

## 5.6.3 Connect the PTC thermistor temperature sensor (PTC)

Connect pump motors equipped with PTC thermistor temperature sensors in the stator winding to a PTC resistor tripping device for protection against overload.

Other proven motor monitoring systems are also possible.



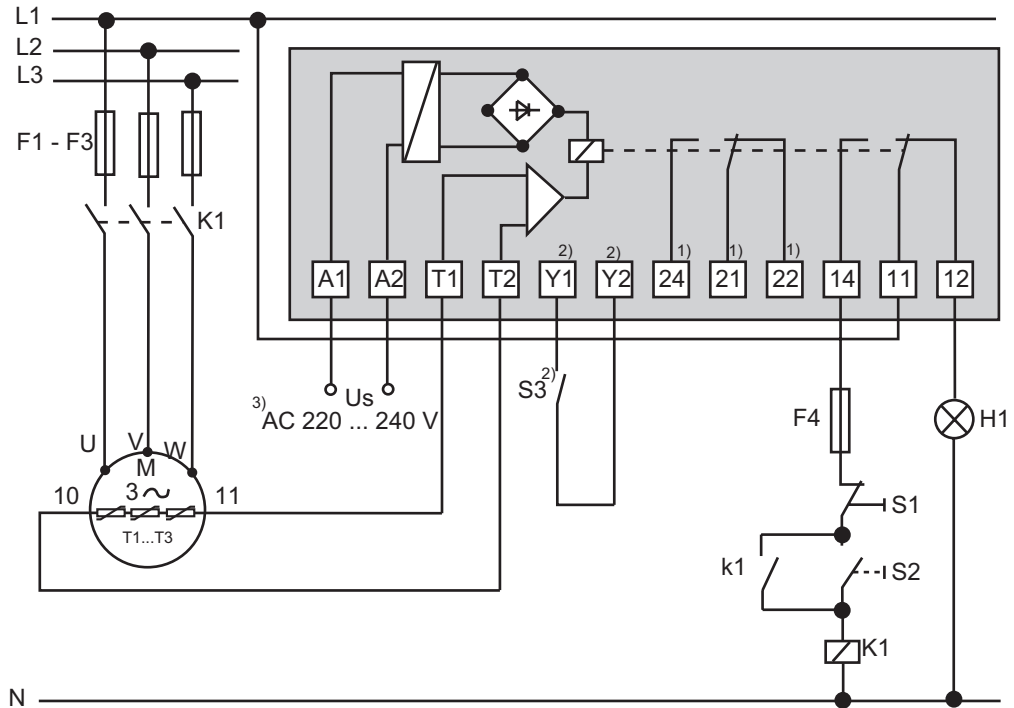

**Fig. 9: Connection example with PTC thermistor tripping unit**

U <sub>s</sub>	Control voltage	T1 – T3	PTC resistor sensor
S <sub>1</sub>	OFF button	H1	Tripping indicator
S <sub>2</sub>	ON button	M	Motor, 3-phase
S <sub>3</sub>	RESET button	1)	For devices with two relay outputs only
K1	Contactor	2)	For MSR type (model) only
F1 – F4	Fuses	3)	Only for order no.: P 4768 052 FQ

**Procedure**

- ▶ After shut-down, switch the tripping unit back on manually via the installed RESET button or via the external RESET S3. Tripping units store the shut-down.
  - Switching on mains detected as automatic RESET.



## 6 Operation

### 6.1 Putting the vacuum pump into operation

#### Before switching on

1. Check the lubricant levels on both sight glasses.
2. Compare the voltage and frequency specifications on the motor rating plate with the available mains voltage and frequency.
3. Make sure that the suction chamber is free from all foreign matters.
4. Check the vacuum pump for visible damage and put the vacuum pump into operation only in a correct state.
5. Protect the vacuum pump from sucking in contamination using suitable measures (e.g. dust filter).
6. Make sure that the shut-off units on the pressure side open before starting the pump.

### 6.2 Switching on the vacuum pump

#### **WARNING**

##### **Danger of poisoning due to toxic process media escaping from the exhaust pipe**

During operation with no exhaust line, the vacuum pump allows exhaust gases and vapors to escape freely into the air. There is a risk of injury and fatality due to poisoning in processes with toxic process media.

- ▶ Observe the pertinent regulations for handling toxic process media.
- ▶ Safely purge toxic process media via an exhaust line.
- ▶ Use appropriate filter equipment to separate toxic process media.

#### **CAUTION**

##### **Danger of burns on hot surfaces**

Depending on the operating and ambient conditions, the surface temperature of the vacuum pump can increase to above 70 °C.

- ▶ Provide suitable touch protection.



#### **Supplementary Information for Roots pumps with special overflow valves**

Upon request, you can obtain supplementary information **PW0022** from [Pfeiffer Vacuum Download Center](#).

#### **Procedure in case of open overflow valve**

1. The customer must provide an appropriate start-up circuit (e.g., contactor circuit) for switching on the Roots pump simultaneously with the backing pump.
2. Allow the vacuum pump to warm up with the vacuum flange closed, for approx. 30 minutes prior to the process start.

The overflow valve is open at the beginning of evacuation in high pressures ranges. This protects the Roots pump from overload. As of a differential pressure below 45 mbar between the suction pressure side, the overflow valve closes.

#### **Procedure in case of a blocked overflow valve**

1. Switch on the Roots pump only at a pressure at which the backing pump can handle over the delivered gas quantity.
2. If you want to switch on the Roots pump at the same time as the backing pump, you must use a frequency inverter to limit the torque in the event of overload.
3. Allow the vacuum pump to warm up with the vacuum flange closed, for approx. 30 minutes prior to the process start.

**Checking the lubricant level**

1. Regularly check the lubricant level while the vacuum pump is running and at operating temperature.
2. Make sure that the level is in the area at the center of the sight glass.
3. Check the lubricant fill level daily during continuous operation or whenever the vacuum pump is switched on.

### 6.3 Adjusting the sealing gas amount

<b>NOTICE</b>
<p><b>Property damage from impermissibly high sealing gas pressure</b></p> <p>Excessive sealing gas pressure leads to damage to the seals after switching on the vacuum pump.</p> <ul style="list-style-type: none"> <li>▶ Observe the max. permissible sealing gas pressure.</li> <li>▶ Reduce the sealing gas pressure to &lt; 1200 hPa.</li> <li>▶ Stop the sealing gas supply immediately after switching off the vacuum pump.</li> </ul>

**Equation for calculating the sealing gas flow:**

$$Q_S = (S_{th} \times p \times A_S) / p_0$$

- $Q_S$  = Sealing gas flow under standard conditions [Nm<sup>3</sup>/h]
- $p$  = Intake pressure [hPa]
- $p_0$  = Ambient pressure under standard conditions [hPa]
- $\Delta p$  = Differential pressure max. [hPa]
- $p_V$  = Fore-vacuum pressure [hPa]
- $A_S$  = Sealing gas content at the operating gas flow ( $0.01 \leq A_S \leq 0.08$ )
- $S_{th}$  = Rated volume flow rate of the roots pump [m<sup>3</sup>/h]

**Procedure**

Depending on the operating pressure, the empirical value for the supplied sealing gas amount is between 1% (for a high operating pressure) and 8% (for a lower operating pressure) of the effective suction capacity. The set quantity of purge gas influences the effective pumping speed and the achievable end pressure.

Inert gases, usually nitrogen (N<sub>2</sub>), are usually used as sealing gas.

1. Open the sealing gas supply on the gas cylinder.
2. Set a max. pressure of 2500 hPa on the pressure reducer.
3. Set the desired quantity of sealing gas on the dosing valve of the inferential meter.

**Example for Okta 1000 G with, e.g., 50 hPa intake pressure and 8 % sealing gas content**

$$Q_S = (1284 \times 50 \times 0.08) / 1013 =$$

$$Q_S = 5.07 \text{ Nm}^3/\text{h}$$

**At discharge pressures > 100 mbar:**

$$Q_S = (S_{th} \times (p_V - \Delta p) \times A_S) / p_0$$

### 6.4 Flushing the suction chamber

<b>NOTICE</b>
<p><b>Property damage from impermissibly high pressure build-up in the suction chamber</b></p> <p>Exceeding the specified flushing quantities damages the vacuum pump.</p> <ul style="list-style-type: none"> <li>▶ Observe the maximum permissible flushing quantities at max. 3000 hPa.</li> <li>▶ Fully purge all supplied fluid.</li> <li>▶ Observe the vapor compatibility of the downstream vacuum pumps.</li> </ul>



**NOTICE****Property damage from incorrect cleaning procedure**

Flushing fluid and process media that enters the bearing and oil chambers will stick.

- ▶ During the cleaning processes, always protect all bearings with sealing gas in order to prevent a contamination of the lubricant and bearing chambers.

If the extracted medium polymerizes or becomes deposited in the suction chamber, a continuous or discontinuous flushing of the suction chamber can be performed during operation.

**Procedure**

1. Consider the materials in contact with a medium when selecting a solvent compatible with the process medium.
  - Materials in contact with the medium are cast iron and steel. Seals are FPM.
2. Select the max. permissible flushing quantity according to the below table.
  - For pumping stations without intermediate condenser or collection receptacles, the smallest vacuum pump in the pumping station determines the fluid quantity.
3. Set the desired flushing quantity at the inferential meter.
4. After flushing, sufficiently dry the vacuum pump on the inside.

Pump type	max. flushing quantity
Okta 18000	3.0 l/min
Okta 8000	2.0 l/min
Okta 6000	1.75 l/min
Okta 4000	1.5 l/min
Okta 2000	1.0 l/min
Okta 1000	0.5 l/min
Okta 250/500	0.25 l/min
Okta 300/600	0.25 l/min

**Tbl. 5: Max. permissible flushing quantity**

## 6.5 Switching off and venting

**⚠ WARNING****Risk of crushing on rotating parts when reaching into the open flange**

The pistons continue to run in the vacuum after switching off the motor, and can trap fingers and hands within their reach.

- ▶ Wait until the vacuum pump comes to a complete standstill.
- ▶ Secure the vacuum pump against re-start.

**NOTICE****Property damage from impermissibly high sealing gas pressure**

Excessive sealing gas pressure leads to damage to the seals after switching on the vacuum pump.

- ▶ Observe the max. permissible sealing gas pressure.
- ▶ Reduce the sealing gas pressure to < 1200 hPa.
- ▶ Stop the sealing gas supply immediately after switching off the vacuum pump.

**Procedure with clean processes**

You can switch off the vacuum pump in every pressure range, between atmospheric pressure and ultimate pressure directly after the process end.

1. Close the shut-off valve in the vacuum line and disconnect the vacuum pump from the process.
2. Switch off the vacuum pump.
3. Vent the vacuum pump via the intake side.



4. Make sure that you do not vent the vacuum chambers through the vacuum pump.
5. Switch off the process- and pump-specific media supply (e.g. the sealing gas supply).

**Procedure with contaminated medium**

With media that heavily contaminate the suction chamber, flush the suction chamber with air or nitrogen at the end of the process.

1. Close the shut-off valve in the vacuum line and disconnect the vacuum pump from the process.
2. At the end of the process, continue to operate the vacuum pump with flushing gas supply at the vacuum flange for another approx. 20 to 40 minutes.
3. Then stop the flushing gas supply.
4. Switch off the vacuum pump.
5. Vent the vacuum pump via the intake side.
6. Make sure that you do not vent the vacuum chambers through the vacuum pump.
7. Switch off the process- and pump-specific media supply (e.g. the sealing gas supply).

## 6.6 Re-start (to)

### NOTICE

**Damage to the roots pump from significant temperature fluctuation**

If the housing cools down too quickly due to external influences, there is a risk of contact being made between the rotor at warm operating temperature, and the colder pump housing. This will result in irreversible pump damage.

- ▶ Avoid uneven cooling, if you are going to switch the roots pump back on after a short period.
- ▶ Vent the roots pump in order to achieve a temperature compensation between the housing and rotor as quickly as possible.



## 7 Maintenance

### 7.1 Maintenance information

#### **WARNING**

##### **Health hazard through poisoning from toxic contaminated components or devices**

Toxic process media result in contamination of devices or parts of them. During maintenance work, there is a risk to health from contact with these poisonous substances. Illegal disposal of toxic substances causes environmental damage.

- ▶ Take suitable safety precautions and prevent health hazards or environmental pollution by toxic process media.
- ▶ Decontaminate affected parts before carrying out maintenance work.
- ▶ Wear protective equipment.

#### **WARNING**

##### **Risk of crushing from rotating parts**

Fingers and hands may be caught by rotating pistons within the connection flange. This results in severe injuries.

- ▶ Keep limbs out of the reach of the roots pump.

#### **Maintenance instructions**

1. Shut down the vacuum pump and allow it to cool if necessary.
2. Vent the vacuum pump to atmospheric pressure via the vacuum side.
3. Safely disconnect the drive motor from the mains.
4. Secure the motor against unintentional reactivation.
5. Remove the vacuum pump from the system if necessary.
6. Dispose of used lubricant according to applicable regulations in each case.
7. For maintenance work, only dismantle the vacuum pump to the extent needed.
8. Only clean the pump parts using industrial alcohol, isopropanol or similar media.
9. Avoid residues of cleaning agent inside the vacuum pump.

### 7.2 Checklist for inspection and maintenance



#### **Notes on maintenance intervals**

Depending on the process, the required maintenance intervals can be shorter than the reference values specified in the table.

- Consult with Pfeiffer Vacuum Service about shorter maintenance intervals for extreme loads or for specific processes.

You can carry out maintenance work at **Maintenance Level 1** yourself.

We recommend Pfeiffer Vacuum Service for carrying out maintenance work of **Maintenance Level 2** and **Maintenance Level 3** (revision). If the required intervals listed below are exceeded, or if maintenance work is carried out improperly, no warranty or liability claims are accepted on the part of Pfeiffer Vacuum. This also applies if original spare parts are not used.



Action	Inspection	Maintenance level 1	Maintenance level 2	Maintenance level 3	Required material
described in document	OI	OI	SI	SI	
Interval	daily	≤ 1 year	≤ 1.5 years	≤ 3 years	
<b>Inspection</b>					
Visual and acoustic pump check <ul style="list-style-type: none"> <li>• Check the lubricant level and color of the lubricant</li> <li>• Check the lubricant level of the sealing oil</li> </ul>	■				
<ul style="list-style-type: none"> <li>• Check the vacuum pump for leaks</li> <li>• Check the vacuum pump for running noises</li> <li>• Check the overflow valve for unusual noises</li> </ul>	■				
<b>Maintenance level 1</b>					
Clean the vacuum pump <ul style="list-style-type: none"> <li>• Pump housing from outside</li> <li>• Rinse the suction chamber with a suitable cleaning agent adapted to the process</li> <li>• Check and clean overflow valve</li> </ul>		■ as required			Lubricant Suitable cleaning agent, compatible with the process
<ul style="list-style-type: none"> <li>• Change the lubricant and sealing oil</li> </ul>		■			
<b>Maintenance level 2</b>					
<ul style="list-style-type: none"> <li>• Check the coupling for damage, replace the toothed ring if necessary</li> <li>• Replace radial shaft seal rings and protective sleeves (for Roots pumps with a radial shaft seal ring)</li> <li>• Clean the gear chambers and replace the seals</li> </ul>			■		Maintenance kit with wearing parts of the coupling and the radial shaft seal rings
<b>Maintenance level 3</b>					





Action	Inspection	Maintenance level 1	Maintenance level 2	Maintenance level 3	Required material
described in document	OI	OI	SI	SI	
Interval	daily	≤ 1 year	≤ 1.5 years	≤ 3 years	
Dismantle and clean the vacuum pump <ul style="list-style-type: none"> <li>• Replace the seals and all wearing parts</li> <li>• Replace 4 piston bearings (ball bearings/roller bearings)</li> <li>• Replace overflow valve wear parts</li> </ul>				■	Overhaul kit Lubricant <b>Option</b> <ul style="list-style-type: none"> <li>• Magnetic coupling set</li> <li>• Set of gear wheels</li> </ul>
Check critical components and replace if necessary: <ul style="list-style-type: none"> <li>• Magnetic coupling (check magnets for damage)</li> <li>• temperature sensor (calibrate the sensor with the reference temperature)</li> <li>• gear wheels (check the teeth for breaks)</li> </ul>				■	

Tbl. 6: Maintenance intervals

### 7.3 Changing the lubricant

**⚠ WARNING**

**Health hazard and environmental damage from toxic contaminated lubricant**

Toxic process media can cause lubricant contamination. When changing the lubricant, there is a health hazard due to contact with poisonous substances. Illegal disposal of toxic substances causes environmental damage.

- ▶ Wear suitable personal protective equipment when handling these media.
- ▶ Dispose of the lubricant according to locally applicable regulations.

**⚠ CAUTION**

**Scalding from hot lubricant**

Danger of scalding when draining lubricant if it comes into contact with the skin.

- ▶ Wear personal protective equipment.
- ▶ Use a suitable collection receptacle.



**Pfeiffer Vacuum recommends determining the precise service life of the lubricant in the first operating year.**

The usable life may deviate from the reference value specified depending on thermic and chemical loads, or due to penetrating process media in gear and bearing chambers.



**Safety data sheets**

You can obtain the safety data sheets for lubricants from Pfeiffer Vacuum on request, or from the [Pfeiffer Vacuum Download Center](#).

**Consumable**

- Lubricant

**Required tool**

- Ring spanner, WAF 17 mm
- Calibrated torque wrench (tightening factor  $\leq 2.5$ )

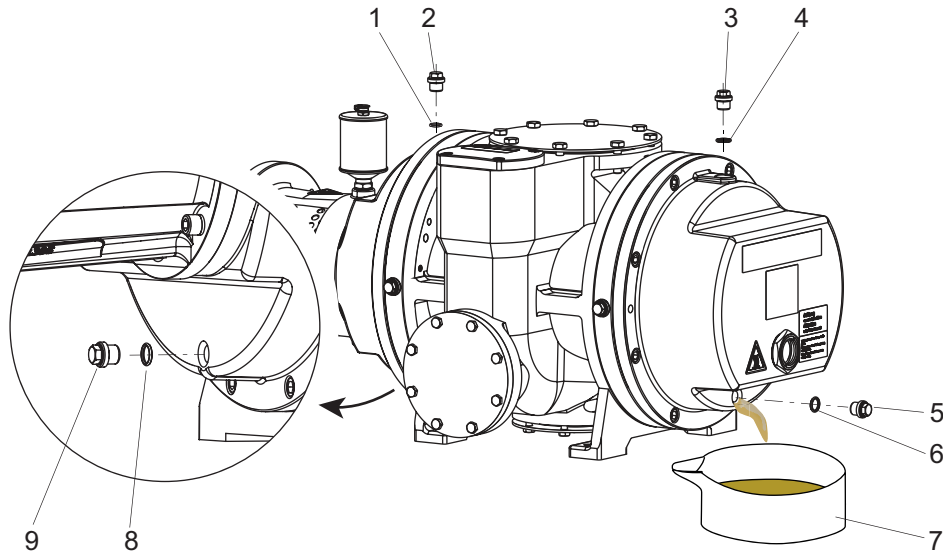

**Fig. 10: Drain the lubricant**

- |                          |                         |
|--------------------------|-------------------------|
| 1 O-ring                 | 6 O-ring                |
| 2 Lubricant filling plug | 7 Collection receptacle |
| 3 Lubricant filling plug | 8 O-ring                |
| 4 O-ring                 | 9 Lubricant drain plug  |
| 5 Lubricant drain plug   |                         |

**Drain the lubricant**

1. Shut down the vacuum pump and allow it to cool if necessary.
2. Vent the vacuum pump to atmospheric pressure via the intake side.
3. Unscrew the lubricant filler screws.
4. Place the collection receptacle underneath.
5. Unscrew both lubricant filler screws.
6. Fully drain the lubricant.
7. Screw the drain screws back in.
  - Tightening torque: **max. 32 Nm**

**Filling with lubricant**

1. Fill the lubricant on both sides until the max. fill level is reached (see chapter “Filling with lubricant”, page 20).
2. Screw in the lubricant filler screws again.
  - Tightening torque: **max. 32 Nm**

## 7.4 Changing the sealing oil



**Overfilling the oiler**

The lubricant expands when the roots pump heats up, which could cause lubricant to leak if overfilled.

Oiler fill level with roots pump in cold state: to max. halfway.

A sealing oil change is required for roots pumps with radial shaft seal ring.

A decreasing oil level in the oiler and an oil leak below the lantern indicate a defective **external** radial shaft seal ring. As long as the oil loss on the oiler is compensated, you may continue operating the roots pump for a certain amount of time.



### Procedure in the event of significant oil loss

A decreasing oil level, with no leaked oil visible below the roots pump, is due to a worn **inner** radial shaft seal ring.

- ▶ Should this occur, arrange for maintenance to be carried out by Pfeiffer Vacuum Service, during which all 3 radial shaft seal rings are generally replaced.
  - This damage leads to an inadmissibly high oil level in the bearing chamber.

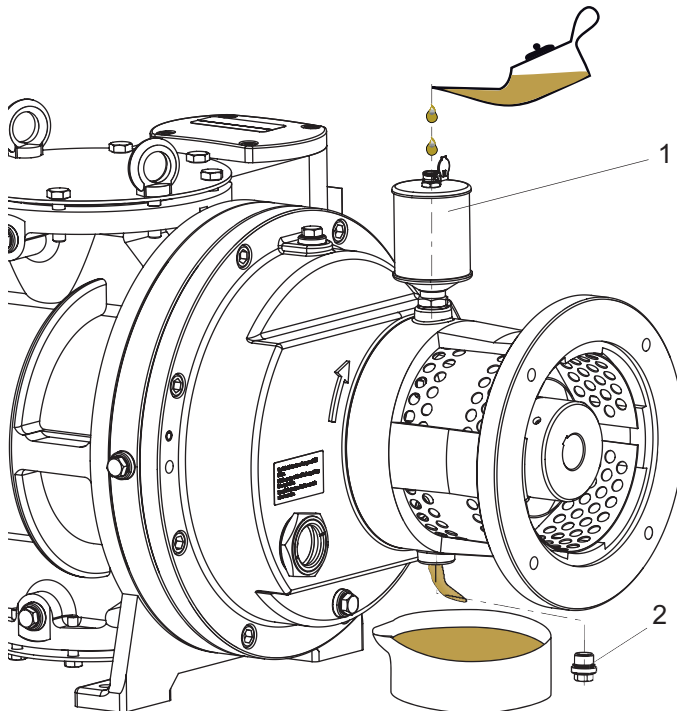

**Fig. 11: Replacing the sealing oil for radial shaft seal rings**

- 1 Oiler                      2 Sealing oil drain screw

### Consumable

- Lubricant

### Required tools

- Open-end wrench, WAF 17
- Calibrated torque wrench (tightening factor  $\leq 2.5$ )

### Procedure for changing sealing oil

1. In general, carry out a sealing oil change once a year.
2. Open the filler flap on the oiler.
3. Place the collection receptacle underneath.
4. Unscrew the sealing oil drain screw.
5. Fully drain the lubricant.
6. Screw the drain screw back in.
  - Tightening torque: **32 Nm**
7. Fill the oiler with lubricant to max. halfway.
8. Close the filler flap.

## 7.5 Cleaning the suction chamber

### **⚠ WARNING**

#### **Risk of crushing from rotating parts**

Fingers and hands may be caught by rotating pistons within the connection flange. This results in severe injuries.

- ▶ Keep limbs out of the reach of the roots pump.



**NOTICE**

**Property damage from incorrect cleaning procedure**

Flushing fluid and process media that enters the bearing and oil chambers will stick.

- ▶ During the cleaning processes, always protect all bearings with sealing gas in order to prevent a contamination of the lubricant and bearing chambers.

The clearance between pistons and housing are within a tenth of a centimeter range. Sustained, accumulating contamination has the following effect:

- the friction heat inside the roots pump increases
- the power consumption of the roots pump increases
- the pistons jam

**Procedure**

1. Dismantle the pipes from the vacuum and fore-vacuum connections.
2. Clean the suction chamber and the overflow channel with suitable brushes and cleaning agents.
3. After cleaning, completely remove remaining fluids using absorbent materials, and dry the suction chamber.
4. After cleaning, mount all pipes.
5. Screw in the drain screws.

**7.6 Cleaning the overflow valve**

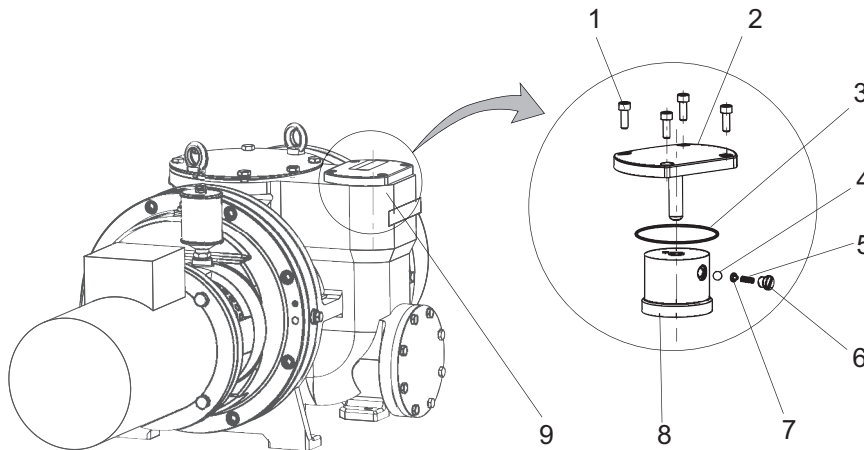

**Fig. 12: Overflow valve**

- |                      |                     |
|----------------------|---------------------|
| 1 Allen head screws  | 6 Pressure screw    |
| 2 Valve cover        | 7 Compression piece |
| 3 O-ring             | 8 Valve plate       |
| 4 Ball               | 9 Pump housing      |
| 5 Compression spring |                     |

**Required tools**

- Allen key, WAF 6 mm
- Calibrated torque wrench (tightening factor  $\leq 2.5$ )

**Remove the overflow valve**

1. Unscrew the screws and remove the valve cover.
2. Be careful with the O-ring.
3. Remove the valve plate from the overflow channel.
4. Unscrew and remove the pressure screw and at the same time remove the compression spring, compression piece, and ball.
5. Clean and dry the guide pin from the valve cover.
6. Lightly rub the surface with emery cloth (grain size 180).
  - Never oil the guide pins, this has an adverse effect on damping.
  - If necessary, replace completely if there are pronounced traces of wear.
7. Clean the other parts.
8. Inspect all parts for wear and replace if necessary.



**Install the overflow valve**

1. Mount the ball, compression piece, and spring.
2. Lock the thread on the pressure screw with **Loctite 243**.
3. Screw in the pressure screw.
4. Locate the valve plate in the overflow channel.
5. Install the O-ring in the appropriate groove.
6. Place the valve cover on the housing.
7. Tighten the screws crosswise.
  - Tightening torque: **25 Nm**

**7.7 Installing the coupling****⚠ WARNING****Danger of injury due to exposed rotating parts**

In the operating range of the motor coupling, there is a danger of clothing being caught and wound up.

- ▶ When assembling the motor and coupling, make sure that the coupling protection is seated correctly.
- ▶ Wear correct clothing.

**Coupling assembly**

Observe the installation instructions of the coupling manufacturer.

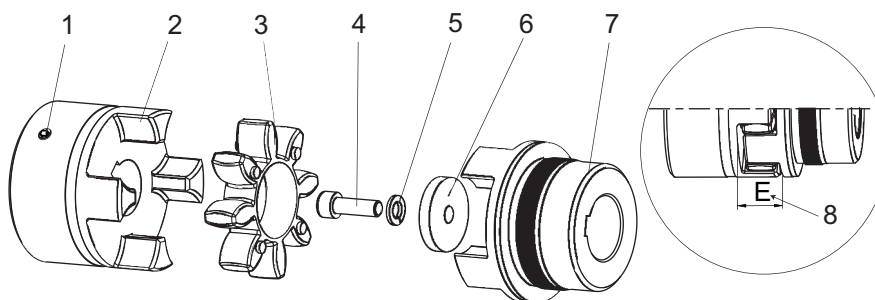

**Fig. 13: Installation instructions gear rim coupling**

- |                              |                           |
|------------------------------|---------------------------|
| 1 Stud screw ( $T_A$ )       | 5 Lock washer             |
| 2 Coupling half motor        | 6 Washer                  |
| 3 Toothed ring coupling hub  | 7 Coupling half pump side |
| 4 Cheesehead screw ( $T_P$ ) | 8 Clearance E             |

**Required tools**

- Allen key, WAF 4 mm
- Allen key, WAF 6 mm
- Calibrated torque wrench (tightening factor  $\leq 2.5$ )

**Procedure**

1. Precisely adhere to the prescribed installation dimensions.
  - Angular and radial displacement of the shafts.
  - Clearance E: 24 mm.
2. Lock the thread on the stud screw with **Loctite 243**.
3. Tighten the stud screw in the motor side coupling half.
  - Tightening torque  $T_A$ : **10 Nm**
4. Install the pump side coupling half.
5. Lock the thread on the cheesehead screw with **Loctite 243**.
6. Install the cheesehead screw with washer and spring washer.
  - Tightening torque  $T_P$ : **32 Nm**



## 7.8 Installing the coupling for versions with magnetic coupling

### **WARNING**

#### **Danger of injury from strong magnetic field**

There is a risk of injury for people with pacemakers and medical implants.

- ▶ Make sure that such individuals do not enter the sphere of influence ( $\leq 2$  m) of the magnetic field.
- ▶ Identify rooms in which magnetic couplings are openly accessible with the symbol: "**No access for people with pacemakers**".
- ▶ Always keep disassembled couplings away from computers, data carriers, and other electronic components.

### **NOTICE**

#### **Damage to the magnetic coupling due to incorrect installation and removal**

The isolating shroud on the magnetic coupling is made of impact-sensitive material (synthetic or ceramic).

If the motor is installed or removed incorrectly, there is a risk of damage.

- ▶ Attach the motor to the lifting gear with the eye bolt and pull the motor horizontally away from the vacuum pump.
- ▶ Use jacking bolts and guide pins.



#### **Supplementary information for work on the magnetic couplings of Roots pumps**

Upon request, you can obtain supplementary information **PW0142** from [Pfeiffer Vacuum Download Center](#).



## 8 Decommissioning

### 8.1 Shutting down for longer periods

Before shutting down the vacuum pump, observe the following instructions to adequately protect the interior of the vacuum pump (suction chamber) from corrosion:

#### Shutting down the vacuum pump

1. Switch off the vacuum pump.
2. Vent the vacuum pump.
3. Allow the vacuum pump to cool down.
4. Clean suction chamber.
5. Change the lubricant.
6. Seal the vacuum and fore-vacuum flanges as well as any other openings with blind flanges from the Pfeiffer Vacuum [accessories range](#).
7. Evacuate the pump interior via the measurement connection on the vacuum side to  $p < 1 \text{ hPa}$ .
8. Fill the suction chamber with nitrogen.
9. Store the vacuum pump in dry, dust-free rooms, within the specified ambient conditions.
10. In rooms with damp or aggressive atmospheres, you should package the vacuum pump in a plastic bag together with a drying agent, and seal it so that it is airtight.
11. For storage durations longer than 2 years, we recommend you carry out maintenance and a lubricant change prior to recommissioning.
12. Please note, the vacuum pump may not be stored in the vicinity of machines, traffic routes, etc., as strong vibrations may damage the bearing.

### 8.2 Recommissioning

#### NOTICE

##### Damage to the roots pump due to aging of the lubricant

The useful life of the lubricant is limited (max. 2 years). Prior to recommissioning, following a shut-down of **2 years or more**, carry out the following work.

- ▶ Observe the maintenance instructions – consult Pfeiffer Vacuum if necessary.
- ▶ Change the lubricant.
- ▶ Check the bearing and if necessary, change the critical elastomer parts.

#### Control work before re-commissioning

1. Check the roots pump for visible damage and put the roots pump into operation only if it is in a correct state.
2. Perform a visual inspection of the pump inner chamber.
3. If drying pearls were inserted in the suction chamber then they should be removed now.
4. If there is evidence of rust on the parts which form the housing then do not put the roots pump into operation and contact [Pfeiffer Vacuum Service](#).
5. If necessary, subject the roots pump to a leak test before re-commissioning.

### 8.3 Disposing of the vacuum pump

#### ⚠ WARNING

##### Health hazard through poisoning from toxic contaminated components or devices

Toxic process media result in contamination of devices or parts of them. During maintenance work, there is a risk to health from contact with these poisonous substances. Illegal disposal of toxic substances causes environmental damage.

- ▶ Take suitable safety precautions and prevent health hazards or environmental pollution by toxic process media.
- ▶ Decontaminate affected parts before carrying out maintenance work.
- ▶ Wear protective equipment.



### Procedure

- ▶ Dispose of all substances safely according to local regulations.





## 9 Malfunctions

### ⚠ CAUTION

#### Danger of burns on hot surfaces

In the event of a fault, the surface temperature of the vacuum pump can increase to above 105°C.

- ▶ Allow the vacuum pump to cool down before working on it.
- ▶ Wear personal protective equipment if necessary.

### NOTICE

#### Danger of property damage from improper maintenance

Unprofessional work on the vacuum pump will lead to damage for which Pfeiffer Vacuum accepts no liability.

- ▶ We recommend taking advantage of our service training offering.
- ▶ When ordering spare parts, specify the information on the nameplate.

Problem	Possible causes	Remedy
Vacuum pump will not start up	<ul style="list-style-type: none"> <li>• Mains voltage is missing or the incorrect operating voltage is present</li> </ul>	<ol style="list-style-type: none"> <li>1. Check the mains voltage.</li> <li>2. Check the mains fuse.</li> <li>3. Check the motor switch.</li> </ol>
	<ul style="list-style-type: none"> <li>• Thermal protection switch has triggered</li> </ul>	<ol style="list-style-type: none"> <li>1. Determine the cause and eliminate the fault.</li> <li>2. Allow the vacuum pump to cool if needed.</li> </ol>
	<ul style="list-style-type: none"> <li>• Suction chamber contaminated</li> </ul>	<ol style="list-style-type: none"> <li>1. Clean suction chamber.</li> <li>2. If necessary, contact Pfeiffer Vacuum Service.</li> </ol>
	<ul style="list-style-type: none"> <li>• Gear (gear wheels) damaged</li> </ul>	<ol style="list-style-type: none"> <li>1. Switch off the vacuum pump immediately.</li> <li>2. If necessary, contact Pfeiffer Vacuum Service.</li> </ol>
	<ul style="list-style-type: none"> <li>• Bearing damage present</li> </ul>	<ol style="list-style-type: none"> <li>1. Have the bearing changed.</li> <li>2. Contact Pfeiffer Vacuum Service.</li> </ol>
	<ul style="list-style-type: none"> <li>• Motor faulty</li> </ul>	<ol style="list-style-type: none"> <li>1. Change the motor.</li> </ol>
Vacuum pump switches off after a while after being started	<ul style="list-style-type: none"> <li>• Thermal protection switch of the motor has triggered</li> <li>• Fore-vacuum pressure possibly too high</li> </ul>	<ol style="list-style-type: none"> <li>1. Determine the cause of the overheating and eliminate the fault.</li> <li>2. Check the fore-vacuum pressure.</li> <li>3. Allow the motor to cool if necessary.</li> </ol>
Vacuum pump/pumping station does not reach ultimate pressure	<ul style="list-style-type: none"> <li>• Suction chamber dirty</li> </ul>	<ol style="list-style-type: none"> <li>1. Clean suction chamber.</li> </ol>
	<ul style="list-style-type: none"> <li>• Lubricant soiled</li> </ul>	<ol style="list-style-type: none"> <li>1. Change the lubricant.</li> </ol>
	<ul style="list-style-type: none"> <li>• Backing pump operates incorrectly</li> </ul>	<ol style="list-style-type: none"> <li>1. Check the backing pump.</li> </ol>
	<ul style="list-style-type: none"> <li>• Leak in system</li> </ul>	<ol style="list-style-type: none"> <li>1. Examine the system for leaks and, if necessary, carry out a leak test.</li> <li>2. Eliminate leaks.</li> </ol>
	<ul style="list-style-type: none"> <li>• Loss of lubricant at the lubricator or the radial shaft seal rings</li> </ul>	<ol style="list-style-type: none"> <li>1. Check the radial shaft seal rings.</li> <li>2. Have the radial shaft seal rings replaced if necessary.</li> <li>3. If necessary, contact Pfeiffer Vacuum Service.</li> </ol>



Problem	Possible causes	Remedy
Unusual noises during operation	<ul style="list-style-type: none"> <li>Suction chamber dirty</li> </ul>	<ol style="list-style-type: none"> <li>Switch off the vacuum pump immediately.</li> <li>Clean suction chamber.</li> </ol>
	<ul style="list-style-type: none"> <li>Damage to the bearing or gear wheels</li> </ul>	<ol style="list-style-type: none"> <li>Switch off the vacuum pump immediately.</li> <li>Contact Pfeiffer Vacuum Service.</li> </ol>
	<ul style="list-style-type: none"> <li>Overflow valve soiled</li> </ul>	<ol style="list-style-type: none"> <li>Switch off the vacuum pump immediately.</li> <li>Clean the overflow valve.</li> </ol>
	<ul style="list-style-type: none"> <li>Damage to motor bearing</li> </ul>	<ol style="list-style-type: none"> <li>Switch off the vacuum pump immediately.</li> <li>Change the motor.</li> <li>If necessary, contact Pfeiffer Vacuum Service.</li> </ol>
	<p><b>Only applies to vacuum pumps with magnetic coupling</b></p> <ul style="list-style-type: none"> <li>Motor is running – vacuum pump is not working, i.e., the magnetic coupling is defective or the magnetic field has broken down.</li> </ul> <p>If the vacuum pump continues to run with a "broken down" magnetic field, the magnetic coupling is destroyed by demagnetization.</p>	<ol style="list-style-type: none"> <li>Switch off the vacuum pump immediately.</li> </ol> <p>While the vacuum pump is at a standstill, the magnets can realign with each other.</p> <ol style="list-style-type: none"> <li>Slowly restart the vacuum pump and check the power transmission and vacuum pressure.</li> </ol>

Tbl. 7: Troubleshooting



## 10 Service solutions from Pfeiffer Vacuum

### We offer first class service

Long vacuum component service life, coupled with low downtimes, are clear expectations that you have of us. We satisfy your needs with capable products and outstanding service.

We are consistently striving to perfect our core competence, service for vacuum components. And our service is far from over once you've purchased a product from Pfeiffer Vacuum. It often enough really just begins then. In proven Pfeiffer Vacuum quality, of course.

Our professional sales engineers and service technicians stand ready to provide hands-on support to you worldwide. Pfeiffer Vacuum offers a complete portfolio of service offerings, ranging from genuine spare parts right through to service agreements.

### Take advantage of Pfeiffer Vacuum Service

Whether for preventative on-site service from our field service, fast replacement with as-new replacement products or repair in a Service Center close to you; you have various options for upholding your equipment availability. Detailed information and addresses can be found on our website in the Pfeiffer Vacuum Service section.

**Advice on the optimum solution is available from your Pfeiffer Vacuum contact partner.**

**For quick and smooth handling of the service process, we recommend the following steps:**

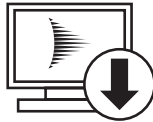

1. Download the current form templates.
  - Declaration of Service Request
  - Service Request
  - Declaration of Contamination

- a. Dismantle all accessories and keep them (all external mounted parts as valve, inlet screen, etc.).
- b. Drain the operating fluid/lubricant as necessary.
- c. Drain the cooling medium as necessary.



2. Fill out the service request and the declaration of contamination.



3. Send the forms via email, fax or post to your local Service Center.



4. You will receive a response from Pfeiffer Vacuum.

PFEIFFER VACUUM

### Sending of contaminated products

No units will be accepted if they are contaminated with micro-biological, explosive or radioactive substances. If products are contaminated or if the declaration of contamination is missing, Pfeiffer Vacuum will contact the customer before starting maintenance. In addition, depending on the product and the level of contamination **additional decontamination costs** may be required.



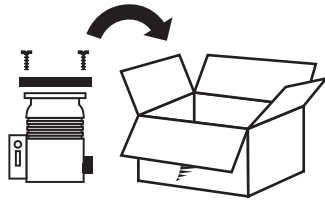

5. Prepare the product for transport in accordance with the details in the declaration of contamination.
  - a) Neutralize the product with nitrogen or dry air.
  - b) Close all openings with airtight blank flanges.
  - c) Seal the product in appropriate protective film.
  - d) Only pack the product in suitable, stable transport containers.
  - e) Observe the applicable transport conditions.
6. Affix the declaration of contamination to the **outside** of the packaging.

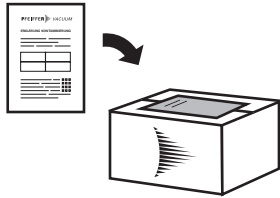

7. Then send your product to your local [Service Center](#).

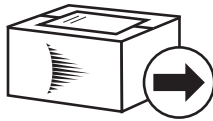

8. You will receive a confirmation message/a quotation from Pfeiffer Vacuum.

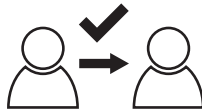

PFEIFFER VACUUM

For all service orders, our [General Terms and Conditions of Sales and Supply](#) and [General Terms and Conditions of Repair and Maintenance](#) apply to vacuum equipment and components.



## 11 Spare parts

- ▶ Have the vacuum pump part number, and any other necessary details from the rating plate, at hand when ordering spare parts.
- ▶ Only use original spare parts.

Article no. of vacuum pump	Pump type	Set of seals	Maintenance kit
PP W41 000 – 020	Okta 1000	PP E10 006 -T	PP E11 005 -T
PP W41 700 – 720	Okta 1000	PP E10 007 -T	PP E11 005 -T
PP W42 000 – 020	Okta 1000 M	PP E10 024 -T	PP E11 010 -T
PP W42 700 – 020	Okta 1000 M	PP E10 024 -T	PP E11 010 -T

Tbl. 8: Available spare parts packages

### 11.1 Set of seals for version with RSSR

The set of seals contains:

- all sealing parts such as O-rings, radial shaft seal rings and supporting rings
- flat seals, square washers and annular profile seals

The protective sleeve and centering rings for connecting the roots pump to the suction and pressure sides are not included.

### 11.2 Set of seals for version with magnetic coupling

The set of seals contains:

- all sealing parts such as O-rings
- flat seals, square washers and annular profile seals

Centering rings for connecting the suction and pressure sides are not included.

### 11.3 Maintenance kit for version with RSSR

The maintenance kit contains:

- all sealing parts in the area of the radial shaft seal ring including the protective sleeve
- all sealing rings of the filling and drain screws and both O-rings for the device cover and cap
- the coupling buffer (toothed ring)

### 11.4 Maintenance kit for version with magnetic coupling

The maintenance kit contains:

- all sealing rings of the filling and drain screws and both O-rings for the device cover and cap
- the O-ring for the isolation shroud

## 12 Accessories



View the line of accessories for Pfeiffer Vacuum roots pumps online at [pfeiffer-vacuum.de](http://pfeiffer-vacuum.de).

### 12.1 Sealing gas device

The use of sealing gas at the bearing points protects the lubricant from contamination by the ingress of process media and flushing fluid into the bearing and oil chambers.

### 12.2 Flushing device

The flushing device is used to clean the materials in contact with the medium if the extracted medium polymerizes or deposits in the suction chamber.

### 12.3 Gear space extraction

The gearbox housing extractor serves to evacuate the gear and bearing chambers in order to shorten pump downtime. The gearbox chamber extractor prevents foaming of the operating resource during pronounced pressure changes.

### 12.4 Protective strainer

The protective strainer on the vacuum connection prevents solids from penetrating into the suction chamber of the vacuum pump.



## 13 Technical data and dimensions

### 13.1 General

Basis for the technical data of Pfeiffer Vacuum roots pumps

- Specifications according to PNEUROP committee PN5
- DIN ISO 21360-1: 2016 "Vacuum technology - Standard methods for measuring vacuum-pump performance - General description"
- Integral leakage rate with 20 % helium concentration, 10 s measurement duration
- Sound pressure level: distance to vacuum pump 1 m

	mbar	bar	Pa	hPa	kPa	Torr   mm Hg
mbar	1	$1 \cdot 10^{-3}$	100	1	0.1	0.75
bar	1000	1	$1 \cdot 10^5$	1000	100	750
Pa	0.01	$1 \cdot 10^{-5}$	1	0.01	$1 \cdot 10^{-3}$	$7.5 \cdot 10^{-3}$
hPa	1	$1 \cdot 10^{-3}$	100	1	0.1	0.75
kPa	10	0.01	1000	10	1	7.5
Torr   mm Hg	1.33	$1.33 \cdot 10^{-3}$	133.32	1.33	0.133	1

$$1 \text{ Pa} = 1 \text{ N/m}^2$$

**Tbl. 9: Conversion table: Pressure units**

	mbar l/s	Pa m <sup>3</sup> /s	sccm	Torr l/s	atm cm <sup>3</sup> /s
mbar l/s	1	0.1	59.2	0.75	0.987
Pa m <sup>3</sup> /s	10	1	592	7.5	9.87
sccm	$1.69 \cdot 10^{-2}$	$1.69 \cdot 10^{-3}$	1	$1.27 \cdot 10^{-2}$	$1.67 \cdot 10^{-2}$
Torr l/s	1.33	0.133	78.9	1	1.32
atm cm <sup>3</sup> /s	1.01	0.101	59.8	0.76	1

**Tbl. 10: Conversion table: Units for gas throughput**

### 13.2 Technical data

Classification	Okta 1000	Okta 1000 M
Version	Standard with motor	Standard with motor and magnetic coupling
Differential pressure at the overflow valve	45 hPa	45 hPa
Flange (in)	DN 160 ISO-F	DN 160 ISO-F
Flange (out)	DN 100 ISO-F	DN 100 ISO-F
Nominal pumping speed	590 – 1 775 m <sup>3</sup> /h	590 – 1 775 m <sup>3</sup> /h
Nominal pumping speed at 50 Hz	1180 m <sup>3</sup> /h	1180 m <sup>3</sup> /h
Nominal pumping speed at 60 Hz	1420 m <sup>3</sup> /h	1420 m <sup>3</sup> /h
Input voltage 50 Hz	230 / 400 V	230 / 400 V
Input voltage 60 Hz	265 / 460 V	265 / 460 V
Input voltage: tolerance	±5 %	±5 %
Rated power 50 Hz	3 kW	3 kW
Rated power 60 Hz	3.5 kW	3.5 kW



Classification	Okta 1000	Okta 1000 M
Nominal rotation speed at 50 Hz	3000 rpm	3000 rpm
Nominal rotation speed at 60 Hz	3600 rpm	3600 rpm
Rotation speed	1 500 – 4 500 rpm	1 500 – 4 500 rpm
Leak rate	$1 \cdot 10^{-3}$ Pa m <sup>3</sup> /s	$1 \cdot 10^{-6}$ Pa m <sup>3</sup> /s
Emission sound pressure level (EN ISO 2151) at intake pressure 10 hPa	75 dB(A)	75 dB(A)
Emission sound pressure level (EN ISO 2151) at intake pressure 1 hPa	72 dB(A)	72 dB(A)
Protection category	IP55	IP55
Cooling method, standard	Air	Air
Motor protection	3TF	3TF
Pumping speed range	1000 m <sup>3</sup> /h	1000 m <sup>3</sup> /h
Operating fluid filling	2.9 l	2.9 l
DN 1	DN 160 ISO-F	DN 160 ISO-F
DN 2	DN 100 ISO-F	DN 100 ISO-F
DN 3	DN 100 ISO-F	DN 100 ISO-F
Ambient temperature	5 – 40 °C	5 – 40 °C
Transport and storage temperature	-10 °C – 40 °C	-10 °C – 40 °C
Weight: with motor	240 kg	275 kg

Tbl. 11: Technical data Okta 1000 Standard | M

### 13.3 Dimensions

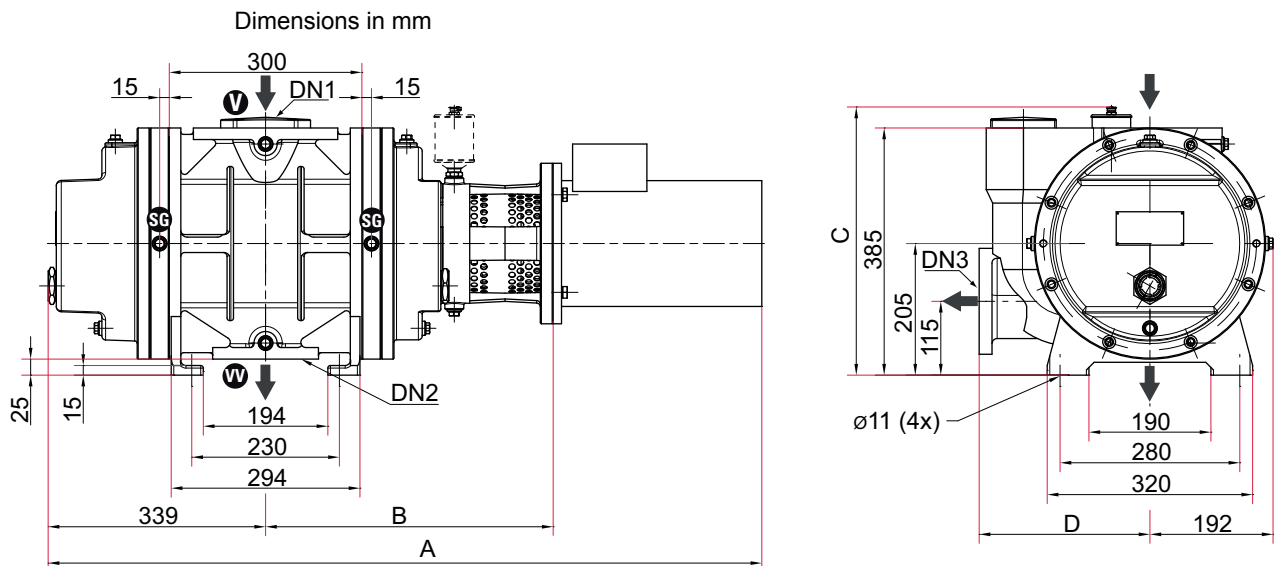

Fig. 14: Dimension diagram Okta 1000 Standard | M

Classification	Okta 1000	Okta 1000 M
A	1112 mm	1125 mm
B	448 mm	461 mm





Classification	Okta 1000	Okta 1000 M
C	418 mm	402 mm
D	266 mm	266 mm

Tbl. 12: Dimensions Okta 1000 Standard | M



# Declaration of conformity

We hereby declare that the product cited below satisfies all relevant provisions of the following EC Directives:

- Machinery 2006/42/EC (Annex II, no. 1 A)
- Electromagnetic compatibility 2014/30/EU
- Restriction of the use of certain hazardous substances 2011/65/EU

The authorized representative for the compilation of technical documents is Mr. Sebastian Oberbeck, Pfeiffer Vacuum GmbH, Berliner Straße 43, 35614 Asslar, Germany.

Roots pump  
**Okta 1000**  
**Okta 1000 M**

#### Harmonized standards and applied national standards and specifications:

DIN EN ISO 12100: 2011  
DIN EN 1012-2: 2011-12  
DIN EN ISO 13857: 2008  
DIN ISO 21360-1 : 2016  
ISO 21360-2 : 2012  
DIN EN ISO 2151: 2009  
DIN EN 60204-1 : 2014

DIN EN 61010-1: 2011  
DIN EN 61000-3-11  
DIN EN 61000-3-12  
DIN EN 61000-6-2: 2006  
DIN EN 61000-6-4: 2007  
DIN EN 60529 : 2014

Signature:

(Dr. Ulrich von Hülsen)  
Managing Director

Pfeiffer Vacuum GmbH  
Berliner Straße 43  
35614 Asslar  
Germany

Asslar, Germany,  
2019-02-16





## VACUUM SOLUTIONS FROM A SINGLE SOURCE

Pfeiffer Vacuum stands for innovative and custom vacuum solutions worldwide, technological perfection, competent advice and reliable service.

## COMPLETE RANGE OF PRODUCTS

From a single component to complex systems:

We are the only supplier of vacuum technology that provides a complete product portfolio.

## COMPETENCE IN THEORY AND PRACTICE

Benefit from our know-how and our portfolio of training opportunities!

We support you with your plant layout and provide first-class on-site service worldwide.

ed. S - Date 1903 - P/N:PP0950BEN



Are you looking for a  
perfect vacuum solution?  
Please contact us

Pfeiffer Vacuum GmbH  
Headquarters • Germany  
T +49 6441 802-0  
info@pfeiffer-vacuum.de

[www.pfeiffer-vacuum.com](http://www.pfeiffer-vacuum.com)

**PFEIFFER**  **VACUUM**

